



UC-251 UC-251S

Frozen Drink Machine Counter Model



This frozen drink machine can do it all – make delicious shakes, slush, smoothies, and frozen cocktails! Use a neutral base with concentrated syrup flavorings for unlimited flavor selection, or specialize in a single flavor for more uniformity and faster dispensing. An optional spindle mixer can be mounted on the freezer to blend in fruits and flavorings. Whether it's signature milk shakes, frozen lemonade, apple cider, or an exotic cocktail, you will create a great deal of interest and fun, while earning big profits.

Features Include:

- Hard-O-Matic consistency control
- Non-frosting, clear molded dispensing head that provides a visually appealing and colorful display
- Low mix warning light
- Designed for fast frezedown and quick recovery
- Decal for slush or shake available



Carpigiani-USA manufactures a complete line of ice cream production equipment: Batch Freezers, Soft Serve Freezers, Yogurt Freezers, Slush Freezers, Milk Shake Machines, Whipped Topping Dispensers, Granita Machines, Frozen Custard Freezers, Mix Processing Equipment and Display Cabinets...

Something for everyone!

SPECIFICATIONS

MODEL UC-251 & MODEL UC-251S



Counter model frozen drink/shake machine.
Designed for medium to high volume applications.

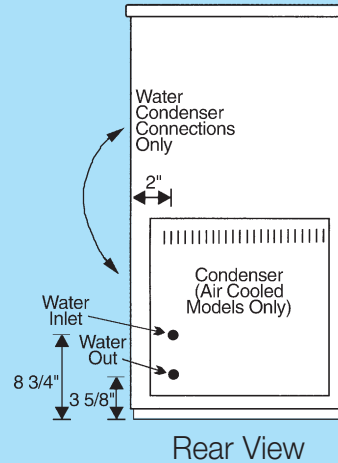
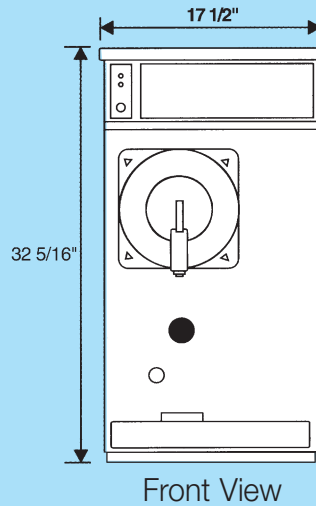
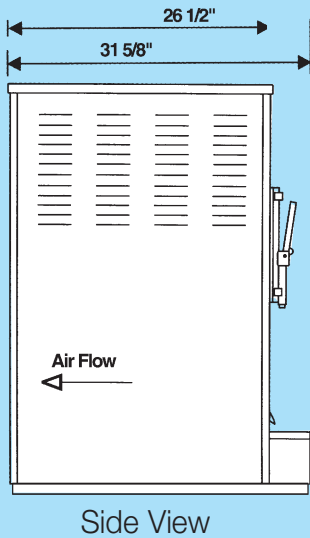
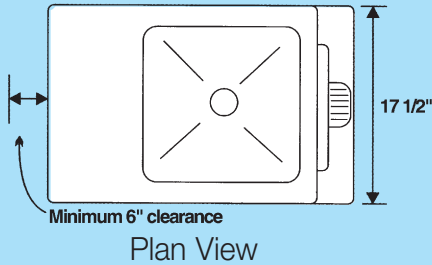

Model UC-251 & UC-251S Description:

Mix Tank Capacity _____ 18 qts.
 Mix Tank Refrigeration Control _____ Thermostat
 Cylinder Refrigeration Control System _____ Hard-O-Matic
 Cylinder Type _____ High Efficiency Wrapped
 Cylinder Capacity (w/beater) _____ 9 qts.
 Refrigerant Type _____ R-404A
 Beater Construction _____ Stainless Steel w/Plastic Scraper
 Beater Drive Motor _____ 0.50 H.P.
 Compressor Motor _____ 1.67 H.P.
 Condenser Cooling _____ Air or Water
 Frame Construction _____ Welded Steel
 Frame Type _____ Counter Model
 Outer Panels _____ Stainless Steel
 Width _____ 17.5 inches (445 mm)
 Depth _____ 31.6 inches (803 mm)
 Height _____ 32.3 inches (820 mm)
 Supply and Drain Lines Diameter _____ .75 inches (19 mm)

Net Weight _____ 260 lbs. (118 kg)
 Gross Weight _____ 285 lbs. (130 kg)

UC-251S

Overrun Range _____ Up to 50%*

Electrical Requirements (UC-251 & UC-251S)

Single Phase, 60 Hz _____ 115 V
 Max Breaker/Fuse Size _____ 30 Amps

Optional Accessories

- Panel mount mixer motor
- Adjustable legs
- Auto Mix Tank Fill (Non-dairy only)

*Applies to shake and similar products



800-648-4389 • 336-661-9893 • Fax: 336-661-9895
 P.O. Box 4069 • Winston-Salem, NC 27115
 www.carpigiani-usa.com • info@carpigiani-usa.com

Distributed by:

All technical data, pictures, and drawings contained in this document are not binding on the manufacturer, nor can the manufacturer be held liable for any modification of the machine in part or completely.