

# CARPIGIANI

## UC-151

### Frozen Drink Machine Counter Model



The UC-151 compact counter model frozen drink machine produces great slush drinks and frozen cocktails. The large clear dispensing head provides a visually appealing and colorful display. The Hard-O-Matic consistency control system results in a smooth, uniform drink. Use a neutral base with concentrated syrup flavoring for unlimited flavor selection, or specialize in a single flavor for more uniformity and faster dispensing. Whether it's frozen lemonade, apple cider, or an exotic cocktail, you will create some real interest and fun while earning big profits.

#### Features Include:

- Low mix warning light
- Continuous beater action attracts attention and maintains product quality
- Yields a premium product that is always ready to serve
- Quick freedown and recovery
- Non-frosting dispensing head
- Drip-free dispensing plunger
- Exceptional product and flavor versatility

# CARPIGIANI

Carpigiani-USA manufactures a complete line of ice cream production equipment: Batch Freezers, Soft Serve Freezers, Yogurt Freezers, Slush Freezers, Milk Shake Machines, Whipped Topping Dispensers, Granita Machines, Frozen Custard Freezers, Mix Processing Equipment and Display Cabinets...

*Something for everyone!*

# SPECIFICATIONS

## MODEL UC-151



Counter model frozen drink machine for medium volume applications

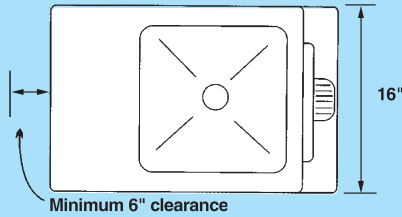

Plan View

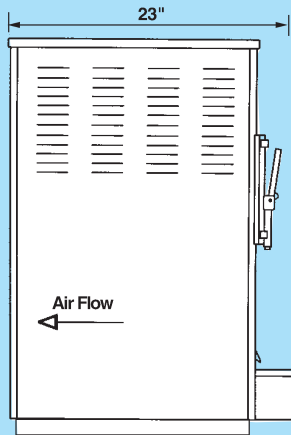

Side View

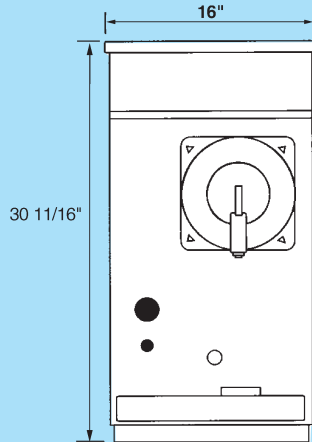

Front View

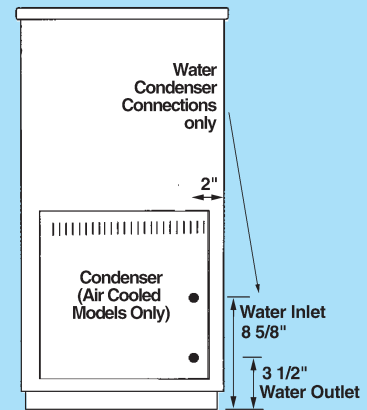

Rear View

### Model UC-151 Description:

Mix Tank Capacity \_\_\_\_\_ 8.5 qts.  
 Mix Feed \_\_\_\_\_ Gravity  
 Cylinder Refrigeration Control System \_\_\_\_\_ Hard-O-Matic  
 Cylinder Type \_\_\_\_\_ High Efficiency Wrapped  
 Cylinder Capacity (w/beater) \_\_\_\_\_ 9 qts.  
 Refrigerant Type \_\_\_\_\_ R-404A  
 Beater Construction \_\_\_\_\_ Stainless Steel w/Plastic Scraper  
 Beater Drive Motor \_\_\_\_\_ 0.33 H.P.  
 Compressor Motor \_\_\_\_\_ 0.75 H.P.  
 Condenser Cooling \_\_\_\_\_ Air or Water  
 Frame Construction \_\_\_\_\_ Welded Steel  
 Frame Type \_\_\_\_\_ Counter Model  
 Outer Panels \_\_\_\_\_ Stainless Steel  
 Width \_\_\_\_\_ 16 inches (406 mm)  
 Depth \_\_\_\_\_ 23 inches (584 mm)  
 Supply and Drain Lines Diameter \_\_\_\_\_ 1/2" (13 mm)

Height \_\_\_\_\_ 30.7 inches (780 mm)  
 Net Weight \_\_\_\_\_ 170 lbs. (77 kg)  
 Gross Weight \_\_\_\_\_ 195 lbs. (89 kg)

### Electrical Requirements

Single Phase, 60 Hz \_\_\_\_\_ 115 V  
 Max Breaker/Fuse Size \_\_\_\_\_ 20 Amps

### Optional Accessories

- Panel mount mixer motor
- Adjustable legs
- Auto Mix Tank Fill



800-648-4389 • 336-661-9893 • Fax: 336-661-9895  
 P.O. Box 4069 • Winston-Salem, NC 27115  
 www.carpigiani-usa.com • info@carpigiani-usa.com

Distributed by:

All technical data, pictures, and drawings contained in this document are not binding on the manufacturer, nor can the manufacturer be held liable for any modification of the machine in part or completely.