

CARPIGIANI

Vision Display Cabinet



DISPLAY AND STORAGE

VISION

IDEAL DISPLAY OPTION FOR LIMITED RETAIL SPACE

With a depth of just 38 inches, this Vision cabinet is the ideal solution for ice cream parlors with limited space.

Sell more per square foot in this **small footprint** – less than 13 square feet for V612. **Extensive selection** – even smallest size holds 12 flavors. **360° display** markets every delicious angle. **Big impact** – sleek look and flattering lighting will **enhance your product** ... and your sales.

The first contact your customers have with your product is the display cabinet. Make the most of that impression with the right lighting, visible flavor labels, and fog-free glass of Carpigiani's Vision cabinet.

Features & Benefits

- Optimal product tempering
 - Uniform cooling
 - Programmable hot gas defrost
 - Electronic controls provide accurate cabinet temperature
- Convenient 115 volt power connection
- Adjustable feet for perfect leveling
- Easy-cleaning
 - Stainless steel work surface
 - Dual front and back access
- Overhead display lighting
- Paintable exterior (additional fee)

CARPIGIANI

800-648-4389 • Fax: 336-661-9895 • P.O. Box 4069 • Winston-Salem, NC 27115
www.carpigiani-usa.com

Learn from the Pros at Carpigiani's hands-on classes
www.frozendessertuniversity.com

CARPIGIANI

SPECIFICATIONS

Vision Display Cabinet

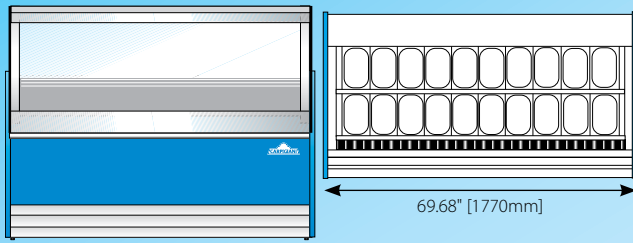

V1020

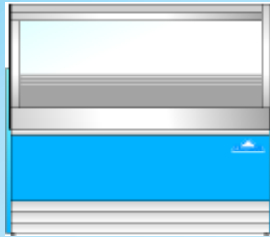

V816

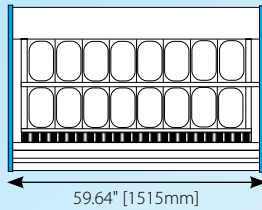

V612

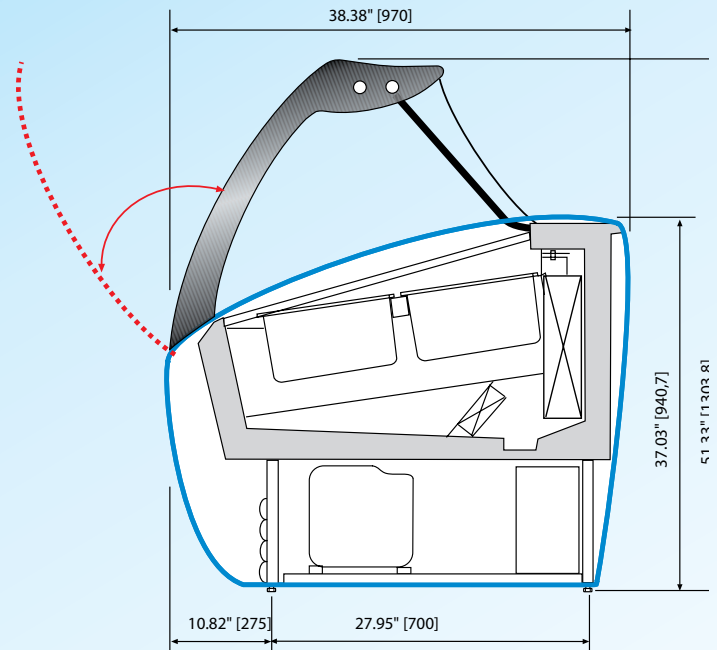
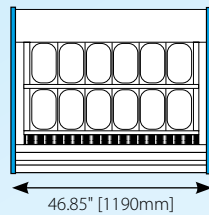

Vision Cabinet Description

Vision	Capacity	Electrical Specifications						Air Temp (F)	Condenser	Refrigerant	Weight	
		Vol.	Hz	Ph	Hp	Amps	Net				Gross	
V1020	20 4-liter pans	115	60	1	3.2	30	-15° to +10	Air	R404A	900 lbs	1102lbs	
V816	16 4-liter pans	115	60	1	2.7	20	-15° to +10	Air	R404A	750 lbs	925 lbs	
V612	12 4-liter pans	115	60	1	2	20	-15° to +10	Air	R404A	615 lbs	770 lbs	

Carpigiani's full product line includes:

Soft Serve Freezers

- **Batch Freezers • Blast Freezers/Hardeners**
- **Yogurt Freezers • Slush/Granita Machines**
- **Whipped Topping and Mousse Dispensers**
- **Frozen Custard Freezers • Milkshake Machines**
 - **Pastry and Chocolate Processors**
 - **Hot Mix Processors • Display Cabinets**
 - **Drinking Chocolate Dispensers**

Distributed by:

All technical data, pictures, and drawing contained in this document are not binding on the manufacturer, nor can the manufacturer be held liable for any modification of the machine, in part or in whole.